

# CONCRETE BOX CULVERT

## Shape and Dimension

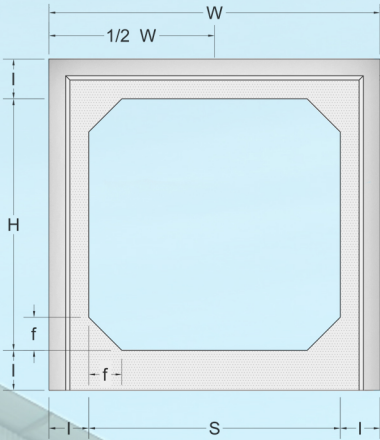

Box Culvert

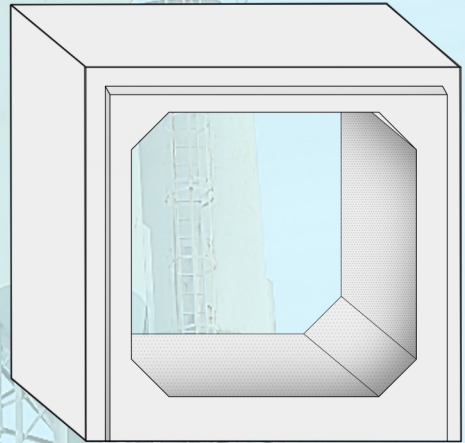

Isometric View

## Spesification

Production Method : Wet Cast High Frequency Vibration (With Steam Curing)

Concrete Quality : Compressive Strength at : 28 days : K-350 Kg/cm<sup>2</sup>

## Dimension of Box Culvert

Type	Size (mm) Wide x Depth x Length	Dimension					Unit Weight (Kg)
		H (mm)	S (mm)	l (mm)	W (mm)	f (mm)	
BC 400	400 x 400 x 1200	400	400	85	570	80	559
BC 500	500 x 500 x 1200	500	500	90	680	85	720
BC 600	600 x 600 x 1200	600	600	95	790	90	895
BC 800	800 x 800 x 1200	800	800	110	1,020	105	1,357
BC 1000 A	1000 x 1000 x 1200	1,000	1,000	125	1,250	120	1,907
BC 1000 B	1000 x 1500 x 1200	1,000	1,500	170	1,340	150	2,558
BC 1200	1200 x 1200 x 1200	1,200	1,200	142	1,784	140	2,584
BC 1500	1500 x 1500 x 1200	1,500	1,500	165	1,784	160	3,725
BC 2000 A	2000 x 1000 x 1200	2,000	1,000	180	2,360	170	4,025
BC 2000 B	2000 x 1500 x 1200	2,000	1,500	200	2,400	190	4,818

### HEAD OFFICE

Jalan Padang By Pass Nagari Kasang,  
Kec. Batang Anai, Padang Pariaman,  
Sumatera Barat -25586  
Telp : 0751-480032 / 483417 / 483527  
Fax : 0751-480033

### MARKETING OFFICE

Jalan Perintis Kemerdekaan Komp.Grand Jati Junction  
Blok T No.9 , Medan, Sumatera Utara

Telp: 061-80513565 / 80513327  
Fax : 061-80514538